

black+blum

LONDON

CO-BRAND & CORPORATE GIFTS



ABOUT US

Founded in 1998 by Dan Black and Martin Blum, Black+Blum is a London-based design company who produce high quality and environmentally friendly lunch boxes, water bottles and thermoses. Unique and sustainable design is at the core of our brand and key to product development; the entire range is made to last and encourages healthy and eco-conscience living.

Our products are ideal for corporate gifting or promotional events, and are easy to customise - partnering with us will promote your brand's environmental credentials to your customers, employees and partners.

We are proud to have membership with:



"We want people who own Black+Blum products to feel great about using them every day."

Dan Black - Co-founder & Lead Designer

OUR PLEDGE TO THE PLANET

Sustainability is at the core of our design philosophy. We work with durable materials, naturally sourced where possible, creating products to be reused for life.

We are proud members of 1% for the Planet which means we commit to giving at least 1% of our sales revenue to non-profit environmental charities. Our chosen charity partners are City Harvest and Trees for Cities. City Harvest rescues surplus food and redistributes it to food banks, schools and community groups. Trees for Cities are the only UK charity working at a national and international scale to improve lives by planting trees in cities.



CO-BRAND

We are an award-winning and globally recognised design brand. We create original, sustainable designs that people love to use and are proud to own. Our products feature regularly in popular media and are sold in the most exclusive shops around the world. Our designs are unique, iconic and functional.

Associate yourself with a product that will make you stand out from the crowd!

It's easy to customise our designs with your logo. Use our guide to create memorable corporate gifts or perfect marketing giveaways.

WHY CO-BRAND?

Whether creating giveaways for an event, or gifting to your clients or employees, using a Black+Blum design will shout volumes about your company. It will show you care about the design you are specifying, and that you care about the planet.

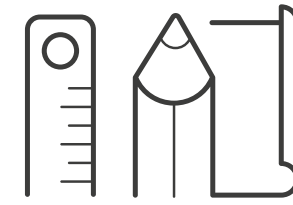

WHY CHOOSE US?

UNIQUE DESIGNS

We create original products that are unique to us (not off-the-shelf items available from other suppliers or factories). We are design innovators and were the first company to offer bamboo lid lunch boxes, 100% leak-proof stainless steel lunch boxes, design led lunch boxes and many more firsts. Find out more about our **design philosophy** and our **founder**.

SUSTAINABLE FOCUS

Our designs are built to last, age well and function perfectly. They are made from quality materials which are food safe, BPA/BPS free and fully recyclable where possible. Our products are designed to be used daily, and will help users lead a more sustainable lifestyle. Find out more about our **materials** and our approach to **sustainable design**. We are members of 1% for the Planet.

HEALTH

Our products help users lead a healthier and more active lifestyle. Whether it is a filter water bottle which encourages you to stay hydrated (and not drink single-use bottled water) or a lunch box that makes it easier to follow a balanced diet with healthy ingredients (and save on food waste), we have it covered.



black+blum

LONDON

CUSTOMISABLE PRODUCT RANGE



LASER MARKING

PERMANENT/DURABLE

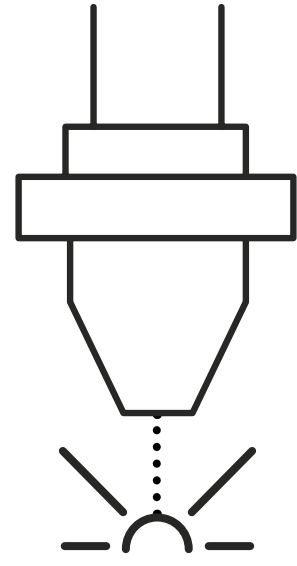

TAMPO/SILK SCREEN

COLOUR PRINT

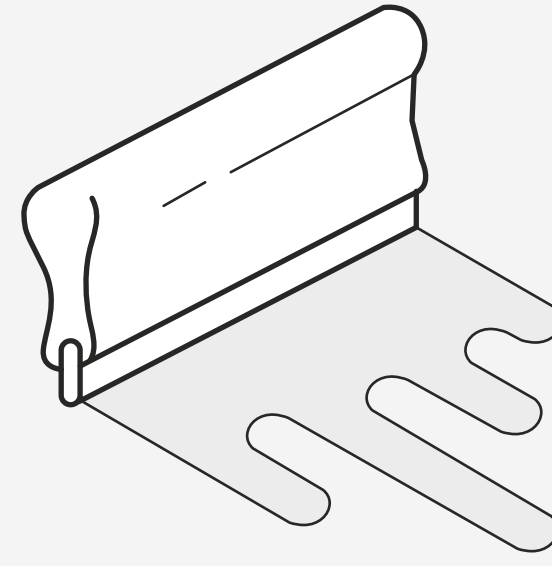

UV DIGITAL PRINT

FULL COLOUR PRINT (*UK ONLY)

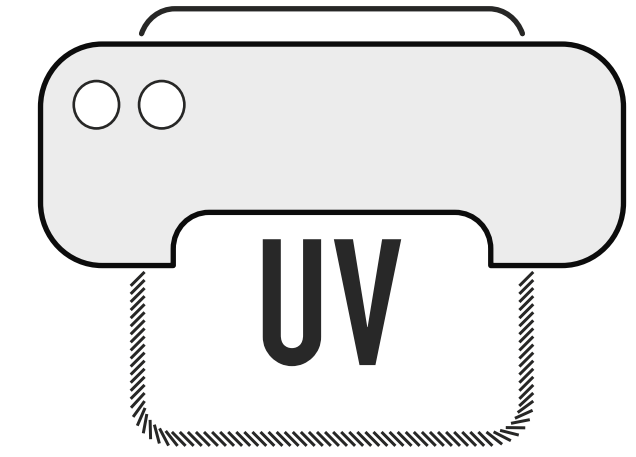

STAINLESS STEEL COLLECTION

One of our most popular ranges, our stainless steel products truly embody the ethos of "buy once, buy well". Built for almost any environment, they are incredibly durable and only get better with age and continuous use.





STEEL BOTTLE

WATCH VIDEO

We've gone back to basics with our single-walled lightweight stainless steel bottle, for those who enjoy the simple things in life. It's easy to use, beautiful in its form and includes a natural cork leak proof lid, with a convenient carry-loop. It's surprisingly compact for its capacity and fits easily into standard bike bottle cages and cup holders.

304 - 18/8 stainless steel, silicone, polypropylene with wood fibre



QUALITY STAINLESS STEEL

600 ml
20 oz



PRODUCT COLOUR OPTIONS

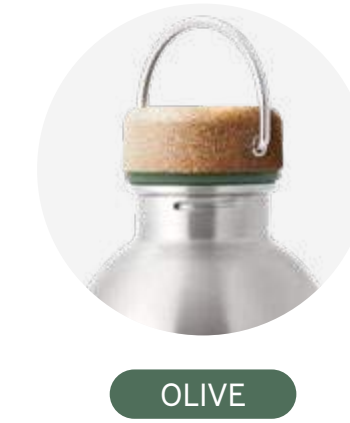

OLIVE

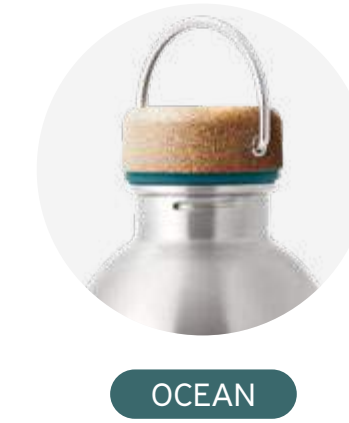

OCEAN



PRINT OR LASER MARKING AREA

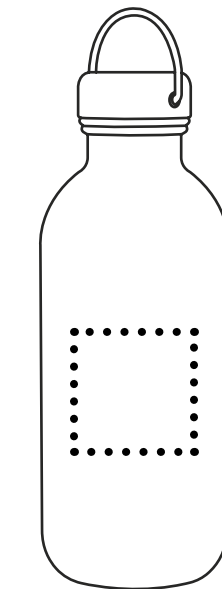

BODY
50 X 50mm
(rotary engraving)
*UK only

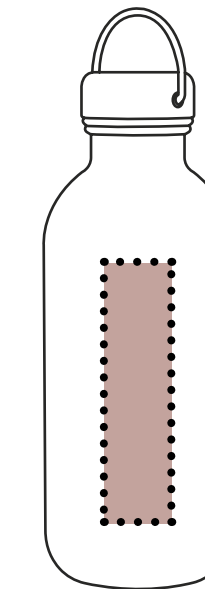

VERTICAL
80 X 28mm

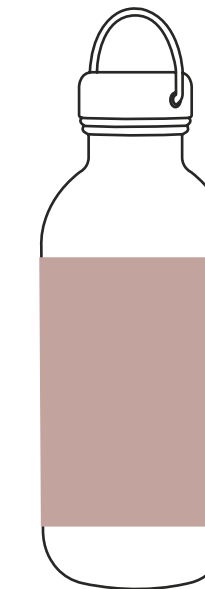

WRAP AROUND
190 X 90mm
(screen print)

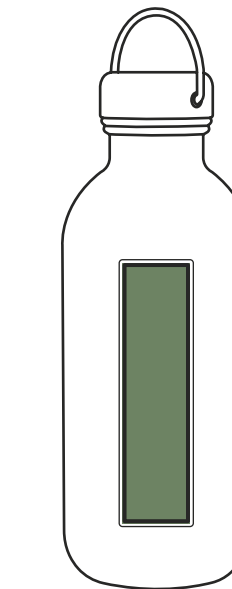

VERTICAL
80 X 25mm

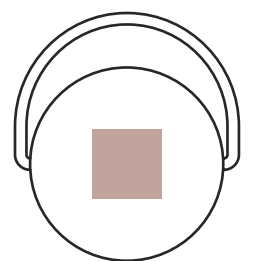

LID - TOP
25 X 25mm

CUSTOMISATION STYLES

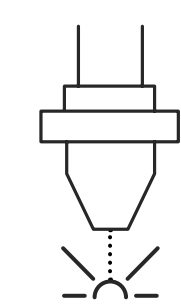

LASER

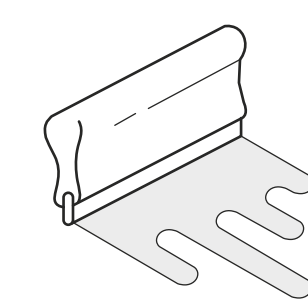

PRINT

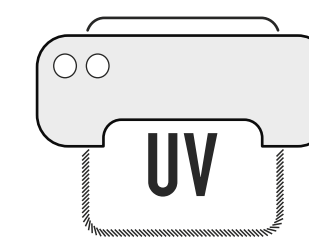

UV PRINT

(*UK only)



EXPLORER BOTTLE

WATCH VIDEO

It's all in the name, this products was made for adventures. We wanted to create something which was a step above our other steel bottles, to deal with the toughest environments. Fully insulated to keep drinks hot or cold for hours. The smooth rim with inside thread makes staying hydrated a dream, and, as always the lid is 100% leak proof. This bottle is truly at home in the great outdoors and will last a lifetime.

304 - 18/8 stainless steel, silicone, nylon



650 ml
22 oz



PRODUCT COLOUR OPTIONS



OLIVE



OCEAN



ORANGE



PRINT OR LASER MARKING AREA

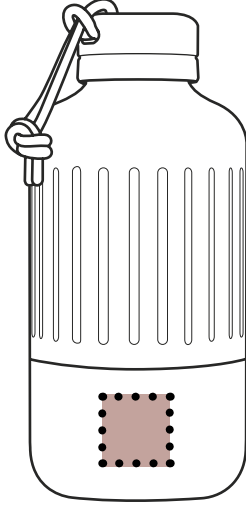

BODY
35 X 35mm

CUSTOMISATION STYLES

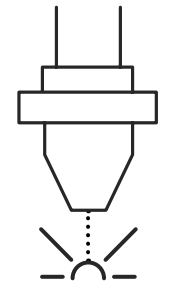

LASER

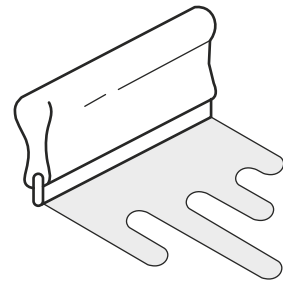

PRINT



EXPLORER BOTTLE LARGE

WATCH VIDEO

It's all in the name, this products was made for adventures. We wanted to create something which was a step above our other steel bottles, to deal with the toughest environments. Fully insulated to keep drinks hot or cold for hours. The smooth rim with inside thread makes staying hydrated a dream, and, as always the lid is 100% leak proof. This bottle is truly at home in the great outdoors and will last a lifetime.

304 - 18/8 stainless steel,
silicone, nylon



850 ml
28.7 oz



PRODUCT COLOUR OPTIONS



OLIVE



OCEAN



ORANGE



PRINT OR LASER MARKING AREA

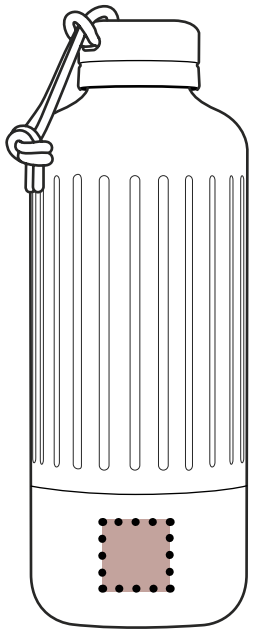

BODY
35 X 35mm

CUSTOMISATION STYLES

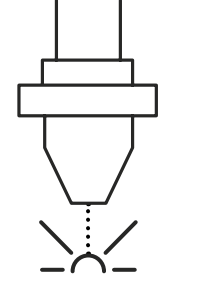

LASER

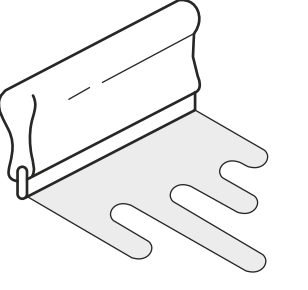

PRINT



INSULATED WATER BOTTLE

[WATCH VIDEO](#)

Keep your drinks cold for up to 24hrs or hot for up to 12hrs in our Insulated Water Bottle. The wide opening allows for easy pouring and cleaning and also accommodates our Binchotan charcoal filter as well as ice-cubes. The vegan leather strap is attached to the stainless steel top so you won't lose it. Our signature style bottle neck has the thread on the inside of the bottle, giving a smooth and comfortable opening from which to drink.

304 - 18/8 stainless steel, vegan leather, silicone



500 ml
17 oz



PRODUCT COLOUR OPTIONS



OLIVE



OCEAN



ORANGE



PRINT OR LASER MARKING AREA

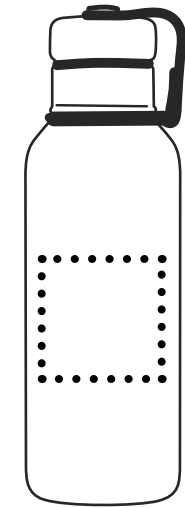

BODY
50 X 50mm
(rotary engraving)
*UK only

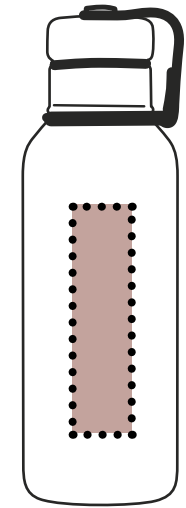

VERTICAL
80 X 28mm

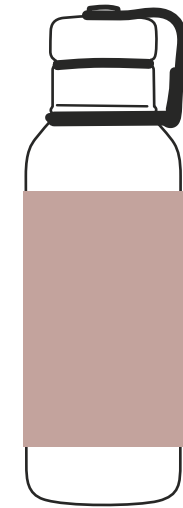

WRAP AROUND
190 X 90mm
(screen print)

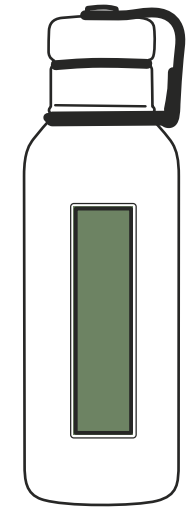

VERTICAL
80 X 25mm

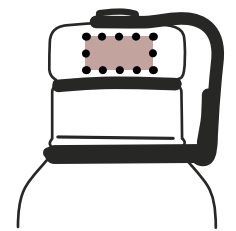

LID - SIDE
20 X 10mm

CUSTOMISATION STYLES

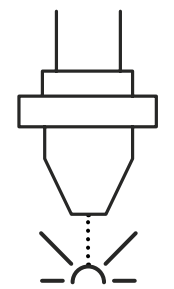

LASER

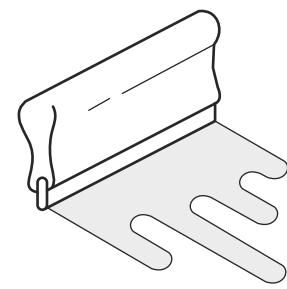

PRINT

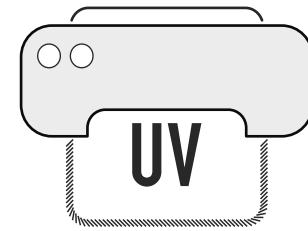

UV PRINT

(*UK only)



INSULATED WATER BOTTLE LARGE

Our Insulated Water Bottle keeps drinks cold for up to 24hrs or hot for up to 12hrs, and the vegan leather strap means no missing lid. Our signature style bottleneck has the thread on the inside, giving a smooth and comfortable opening and the wide spout allows for easy pouring. This bottle is a favourite among urban commuters and countryside walkers alike, comes in 3 colours and is 100% leak proof.

304 - 18/8 stainless steel,
vegan leather, silicone



750 ml
25 oz

PRODUCT COLOUR OPTIONS



OLIVE



OCEAN



ORANGE



PRINT OR LASER MARKING AREA

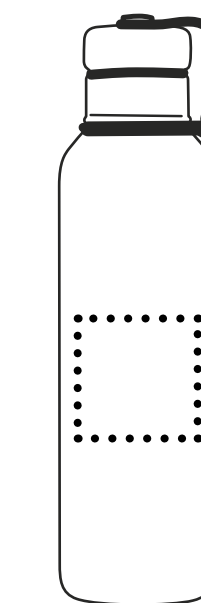

BODY
50 X 50mm
(rotary engraving)
*UK only

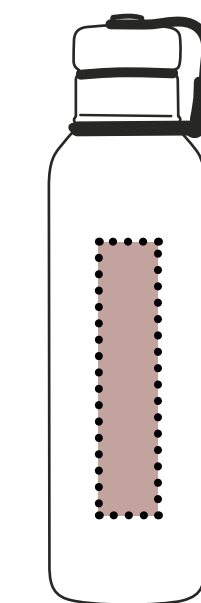

VERTICAL
100 X 28mm



WRAP AROUND
190 X 150mm
(screen print)

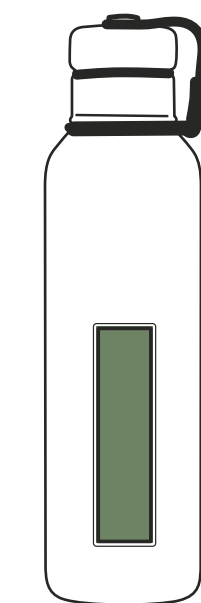

VERTICAL
80 X 25mm

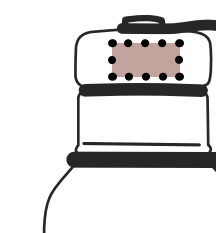

LID - SIDE
20 X 10mm

CUSTOMISATION STYLES

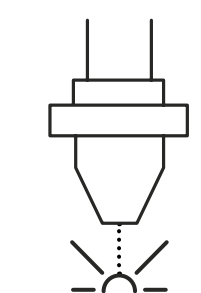

LASER

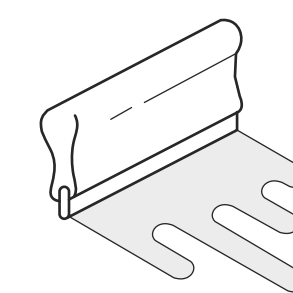

PRINT

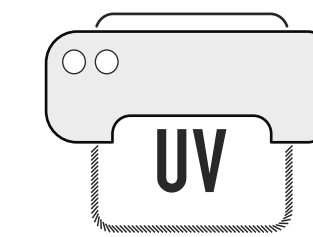

UV PRINT

(*UK only)



BENTO BOX

WATCH VIDEO

Designed in collaboration with bento expert, Sara Kiyo Popowa, and taking inspiration from Japan, it is one of the first fully leak proof steel bentos on the market. Reflecting traditional proportions whilst maintaining the Black+Blum design aesthetic, it includes two identical boxes which stack neatly atop each other. A steel fork is hidden beneath the antibacterial bamboo lid and each box has a generous capacity of 500ml, so can be used individually or as a pair. Breakfast and lunch, lunch and snacks, this box is all you need for the day.

304 - 18/8 stainless steel, polypropylene with wood fibre, silicone, nylon, natural bamboo

-
-
-
-
- 2 x 500 ml
2 x 17 oz



PRINT OR LASER MARKING AREA

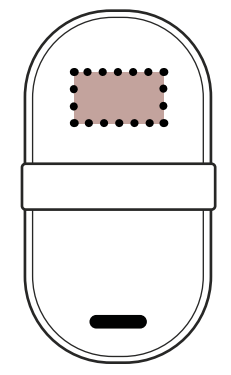

LID - TOP
60 X 35mm

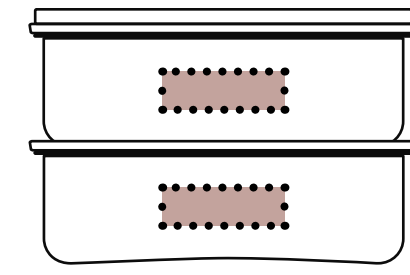

LONG SIDE
60 X 20mm

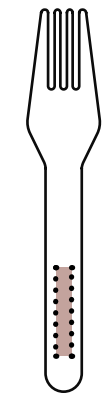

FORK
40 X 10mm



CUSTOMISATION STYLES

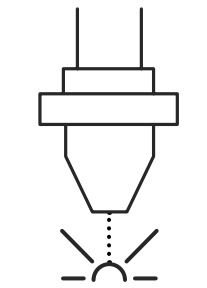

LASER

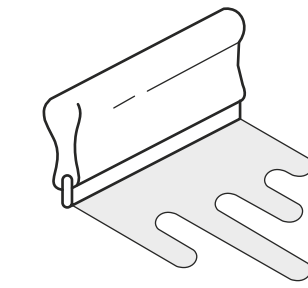

PRINT



SANDWICH LUNCH BOX

WATCH VIDEO

Made from high quality stainless steel with a naturally antibacterial bamboo lid and a silicone band. The lid doubles as a chopping board or serving plate, and the larger size includes a silicone compartment which is microwave-safe. The lid is held securely in place by a silicone strap so everything stays safe inside - this box is perfect for the park, the commute and the trail.

304 - 18/8 stainless steel, natural bamboo, silicone

BPA FREE

QUALITY STAINLESS STEEL

NATURAL BAMBOO

**900 ml
30 oz**



PRODUCT COLOUR OPTIONS



OLIVE

OCEAN

ORANGE

PRINT OR LASER MARKING AREA

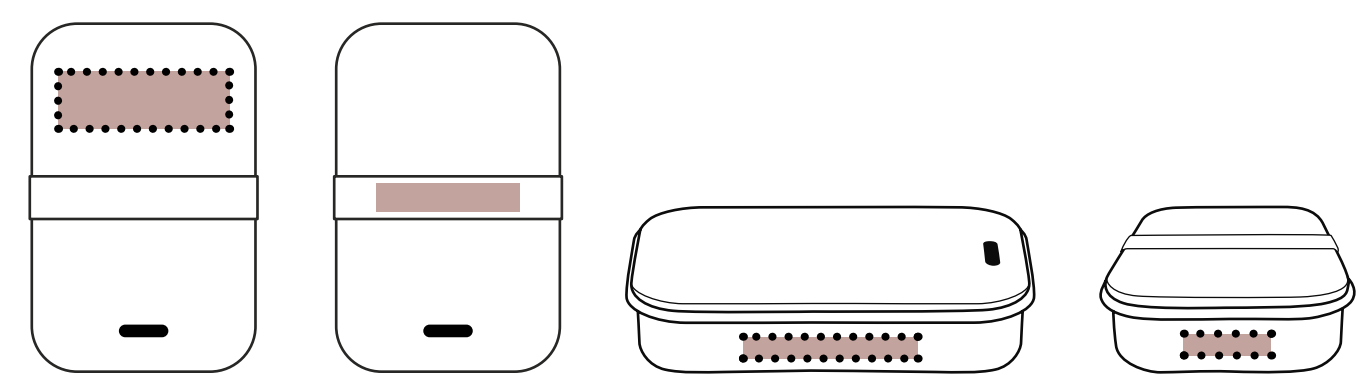

LID - TOP
110 X 40mm

STRAP (screen print)
100 X 15mm
black & white

BOX - LONG SIDE
120 X 15mm

BOX - SHORT SIDE
60 X 15mm

CUSTOMISATION STYLES

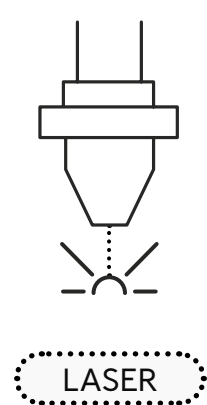

LASER

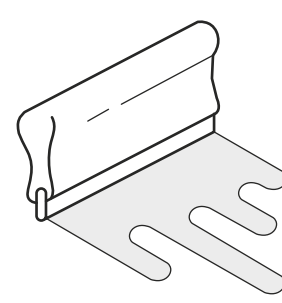

PRINT



SANDWICH LUNCH BOX LARGE

WATCH VIDEO

Finally, a box that can hold an apple, orange or even an avocado, with a sandwich and a drink. As a bonus there is an inner container that you can use to separate your food and put in the microwave for re-heating if desired. You can also prepare your food on-the-go with the anti-bacterial bamboo lid which doubles as a chopping board. The over-moulded silicone seal is designed for longer life and easy cleaning.

304 - 18/8 stainless steel, natural bamboo, silicone

**BPA
FREE**

**QUALITY
STAINLESS
STEEL**

**NATURAL
BAMBOO**

**1.25 L
42 oz**



PRODUCT COLOUR OPTIONS



PRINT OR LASER MARKING AREA

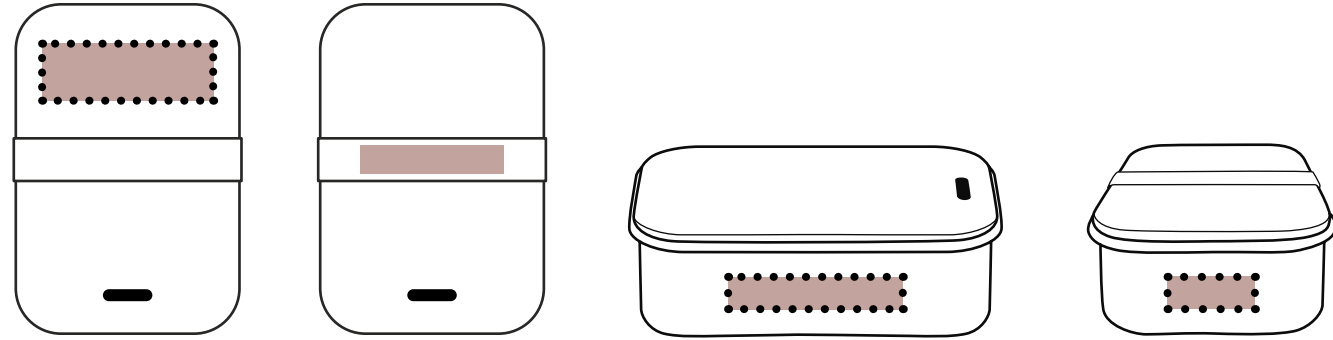

LID - TOP
100 X 40mm

STRAP (screen print)
100 X 15mm
black & white

BOX - LONG SIDE
120 X 20mm

BOX - SHORT SIDE
60 X 20mm

CUSTOMISATION STYLES

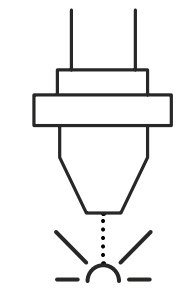

LASER

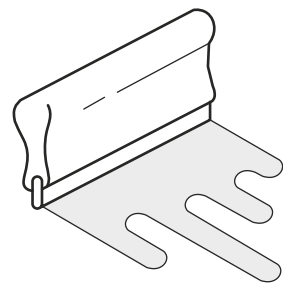

PRINT



STEEL LUNCH BOX

WATCH VIDEO

The ultimate product for outdoor adventurers and busy commuters, this design is incredibly sturdy and a favourite among those living plastic-free and zero-waste. The silicone valve creates a secure and leak proof vacuum-sealed closure, it has a stainless steel fork and coloured silicone strap for added security.

304 - 18/8 stainless steel, silicone

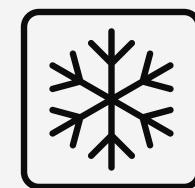

QUALITY
STAINLESS
STEEL

600 ml
20 oz



PRODUCT COLOUR OPTIONS



OLIVE



OCEAN



ORANGE



PRINT OR LASER MARKING AREA

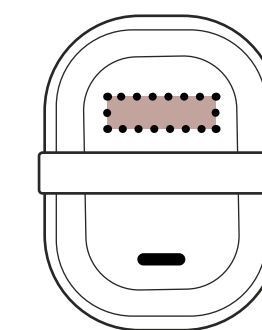

LID - TOP
65 X 30mm

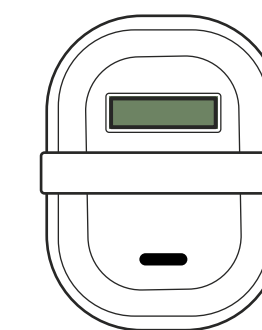

LID - TOP
65 X 30mm

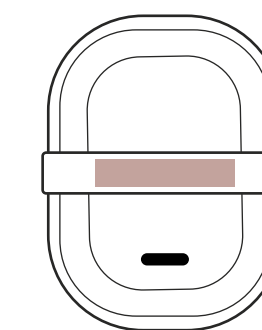

STRAP (screen print)
100 X 15mm
black & white

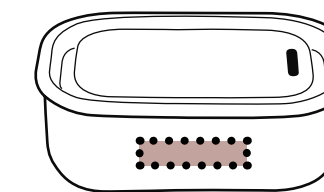

LONG SIDE
60 X 15mm

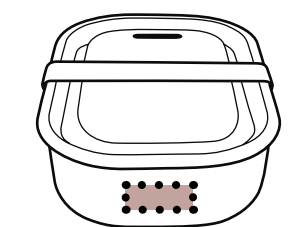

SHORT SIDE
25 X 15mm



FORK
40 X 10mm

CUSTOMISATION STYLES

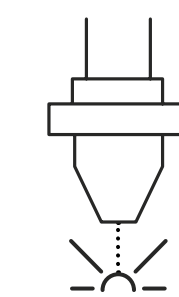

LASER

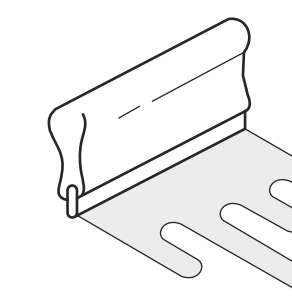

PRINT

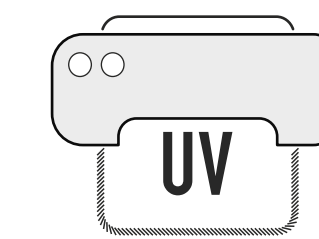

UV PRINT

(*UK only)



STEEL LUNCH BOX LARGE

WATCH VIDEO

Our Stainless Steel Lunch Box is the first truly leak-proof box with 3-in-1 multi-functionality, meaning you can transport your lunch, cook dishes in the oven, and even store pre-cooked meals in a freezer. The silicone valve creates a secure vacuum-sealed closure, the adjustable divider allows you to separate food, and the fork and strap are added for convenience.

304 - 18/8 stainless steel, silicone

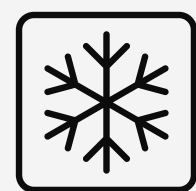

QUALITY
STAINLESS
STEEL

1 L
34 oz



PRODUCT COLOUR OPTIONS



OLIVE



OCEAN



ORANGE



PRINT OR LASER MARKING AREA

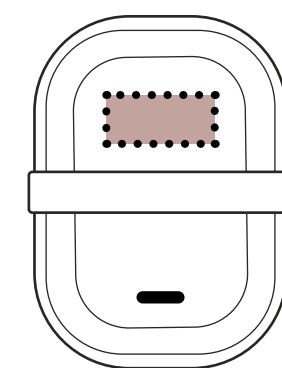

LID - TOP
70 X 40mm

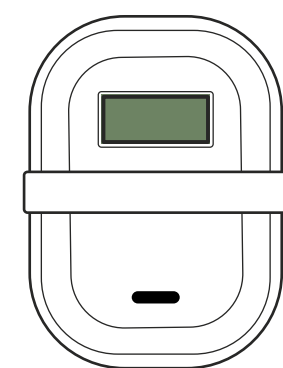

LID - TOP
70 X 40mm

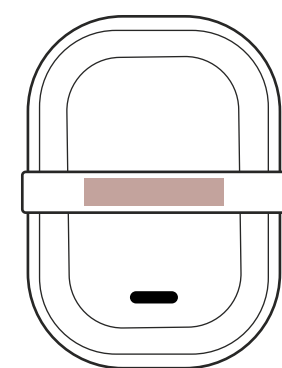

STRAP (screen print)
100 X 15mm
black & white

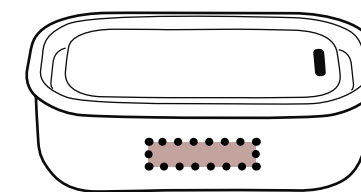

LONG SIDE
80 X 20mm

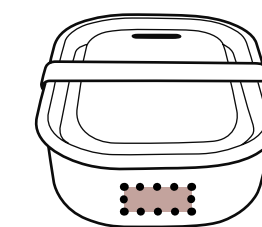

SHORT SIDE
30 X 20mm



FORK
40 X 10mm

CUSTOMISATION STYLES

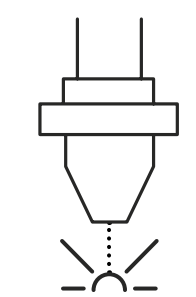

LASER

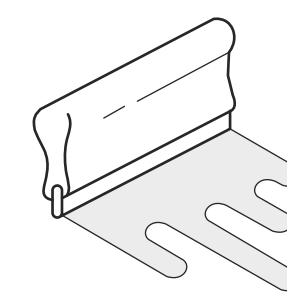

PRINT

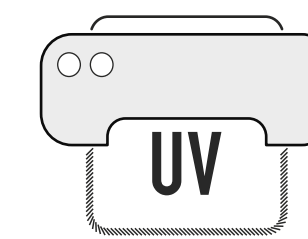

UV PRINT

(*UK only)



FOOD FLASK

WATCH VIDEO

Insulated stainless steel and 100% leak proof, the Food Flask is vacuum-sealed, keeping food hot for up to 6 hours, or cold for 8. The lid has a full-steel underside, so there's no plastic contact with food, and comes with a wood fibre polypropylene spoon, which fits snugly to the side. It's held in place by a nylon strap which comes in 3 colours. A generous capacity in a compact package, it's simple, sleek and made to last.

304 - 18/8 stainless steel, polypropylene, silicone, nylon, polypropylene with wood fibre



400 ml
13.5 oz



PRODUCT COLOUR OPTIONS



OLIVE



OCEAN



ORANGE



PRINT OR LASER MARKING AREA

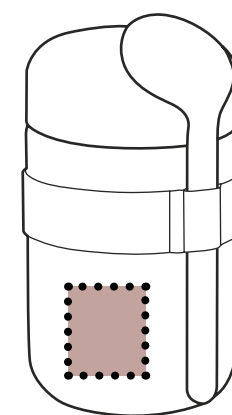

BODY
40 x 40mm

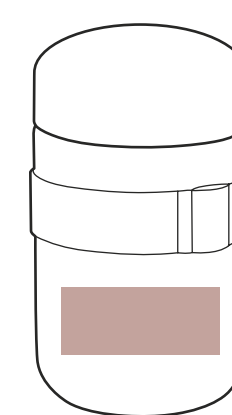

WRAP AROUND
70 X 30mm
(screen print)

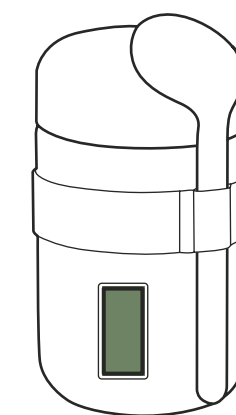

BODY
40 X 20mm

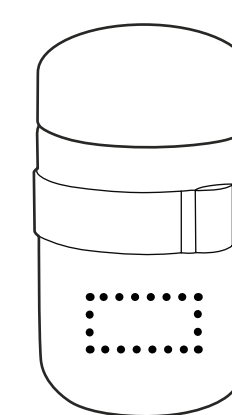

WRAP AROUND
50 X 30mm
(rotary engraving)
*UK only

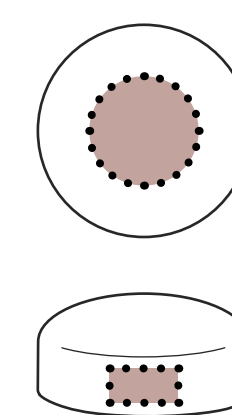

LID
TOP - ø45mm
SIDE - 40 x 10mm

CUSTOMISATION STYLES

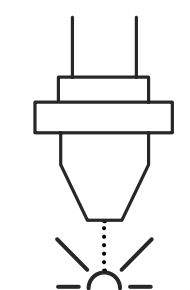

LASER

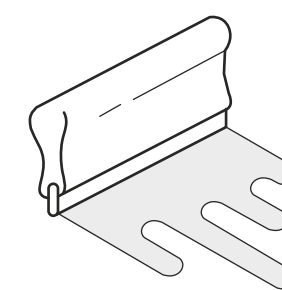

PRINT

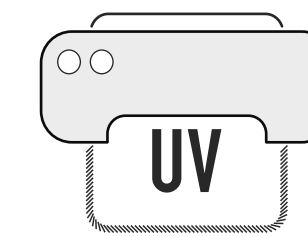

UV PRINT

(*UK only)



THERMO POT

WATCH VIDEO

Vacuum insulated and 100% leak proof, the Thermo Pot keeps food hot for up to 6 hours, or cold for 8. The natural cork lid is water-repellent, and has thumb grooves to give you extra grip when opening. It includes a stainless steel spoon held in place by a nylon strap. Elegant and minimalist design, this product was created to come with you, where ever you want to go.

304 - 18/8 stainless steel, polypropylene, silicone, nylon, natural cork



550 ml
18.5 oz



PRINT OR LASER MARKING AREA

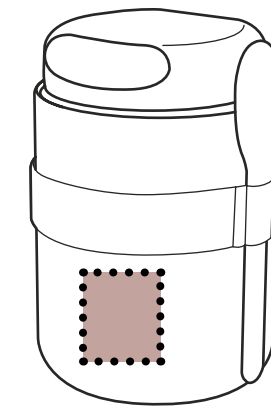

BODY
40 x 40mm

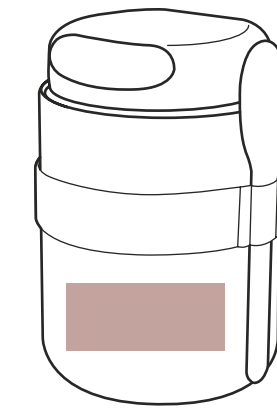

WRAP AROUND
70 X 30mm
(screen print)

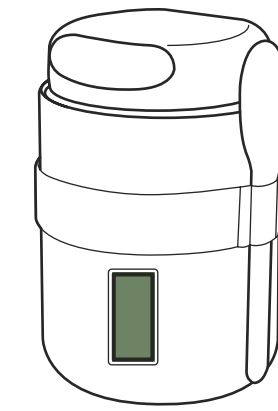

BODY
40 X 20mm

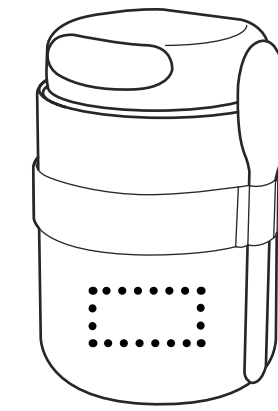

WRAP AROUND
50 X 30mm
(rotary engraving)
*UK only

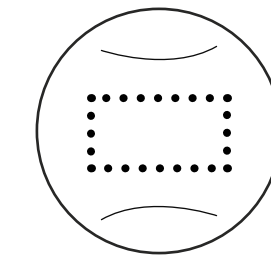

LID
40 X 50mm

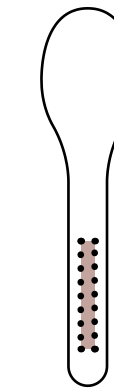

LID
50 X 10mm



CUSTOMISATION STYLES

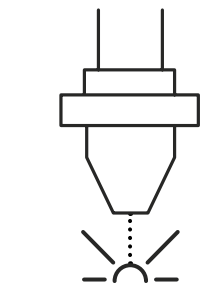

LASER

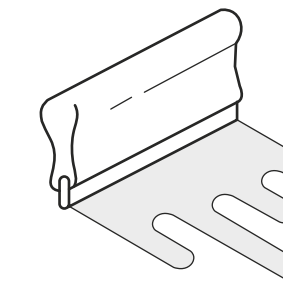

PRINT

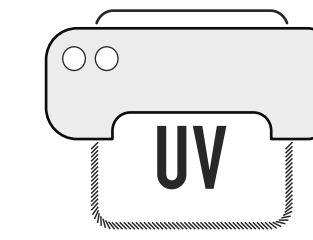

UV PRINT
(*UK only)

TRAVEL CUPS

Eliminating the need for single-use cups, from the café or from home, on your commute or on the trail – our new Travel Cup has perfected the experience of taking your brew with you, wherever you want to go.

It took us three years to test and improve on existing products in this established and highly competitive market, and we only wanted to release this range if it was truly new and better than what was available. We have created our own unique designs – Two Travel Cups, both 100% leak proof but answering different needs and priorities – taste-neutral glass for flavour connoisseurs or insulated stainless steel to keep drinks hot or cold for hours.





INSULATED TRAVEL CUP

[WATCH VIDEO](#)

Made from high quality stainless steel, it will keep your drinks hot for up to 5 hours, or cold for 8. The lid is 100% leak proof, lockable and easy to disassemble to clean. This is a no-nonsense, designed to function travel cup that will last you a lifetime.

304 - 18/8 Stainless steel, silicone, polypropylene, nylon, POK, POM



340 ml
12 oz



PRODUCT COLOUR OPTIONS



OLIVE



OCEAN



ORANGE



SLATE



PRINT OR LASER MARKING AREA

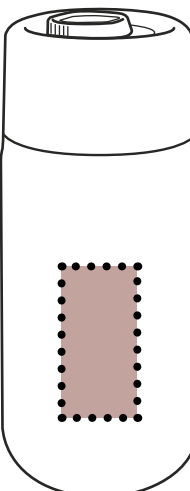

BODY
28 X 60mm

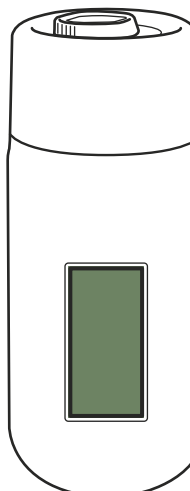

BODY
28 X 60mm

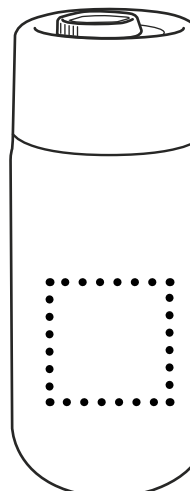

BODY
50 X 50mm
(rotary engraving)
*UK only

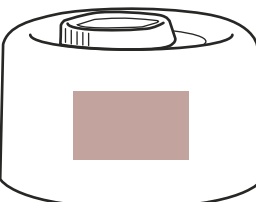

LID
35 x 20mm

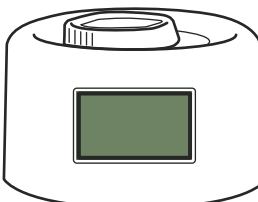

LID
30 x 20mm

CUSTOMISATION STYLES

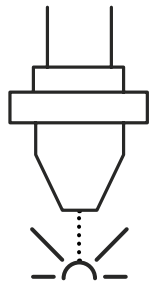

LASER

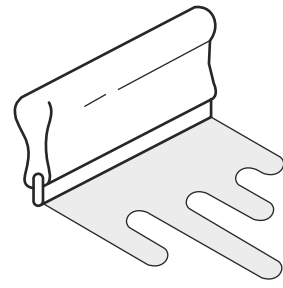

PRINT

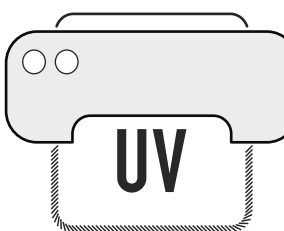

UV PRINT

(*UK only)



GLASS TRAVEL CUP

WATCH VIDEO

Crafted from lightweight borosilicate glass, this design will give you a completely taste-neutral experience for either your favourite home brew or coffee shop roast. The non-slip insulating silicone sleeve gives protection to the surprisingly tough glass inner, and ensures you don't burn your hands. The top is 100% leak proof, lockable and easy to dismantle for thorough cleaning.

Borosilicate glass, silicone, polypropylene, nylon, POK, POM



340 ml
12 oz



PRODUCT COLOUR OPTIONS



OLIVE



OCEAN



CORAL



SLATE



PRINT OR LASER MARKING AREA

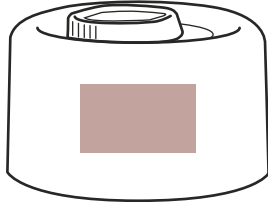

LID
35 x 20mm
(*UK and EU only)

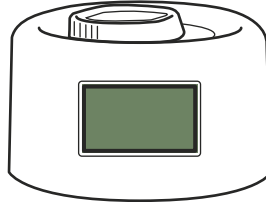

LID
30 x 20mm

CUSTOMISATION STYLES

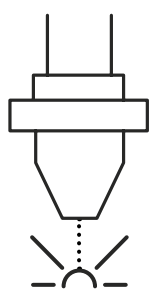

LASER

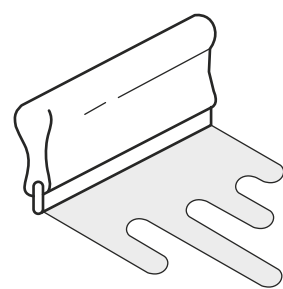

PRINT

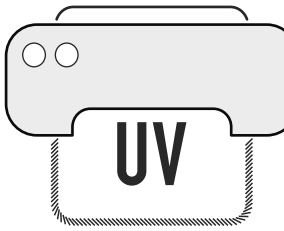

UV PRINT

(*UK only)

GLASS COLLECTION

A material used to store goods for centuries, glass has a variety of benefits; taste-neutral, fully recyclable, and aesthetically pleasing. Many of our glass products are made with borosilicate glass, known for its lightweight but durable qualities. All of our glass lunch boxes and water bottles are 100% leak proof and come in a range of different sizes and colours.





GLASS WATER BOTTLE

[WATCH VIDEO](#)

We wanted to create a minimal design that felt sturdy and authentic, allowing you to enjoy the simplicity that comes with drinking from glass. The thread on the inside of the neck means it has a smooth edge surface, making it easier, and more enjoyable to drink from. The 100% leak proof lid features high quality stainless steel inside, ensuring no plastic contact with water. A protective non-slip silicone sleeve provides a reassuring grip and comes in 7 different colours.

Borosilicate glass, 304 - 18/8 stainless steel, nylon, polypropylene, silicone



600 ml
20 oz



PRODUCT COLOUR OPTIONS



OLIVE OCEAN SLATE ORANGE CORAL BURGUNDY

PRINT AREA

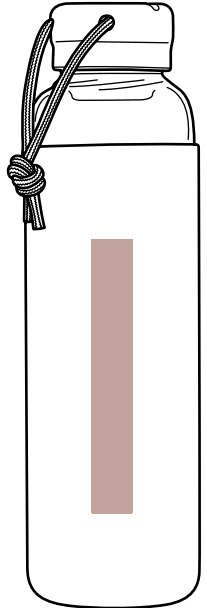

VERTICAL
100 X 25mm

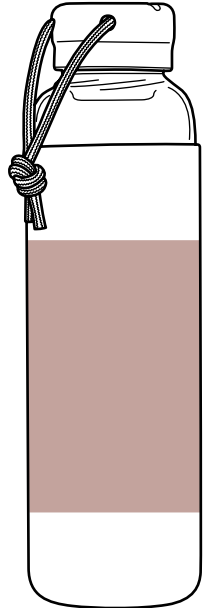

WRAP AROUND
100 X 100mm (screen print)

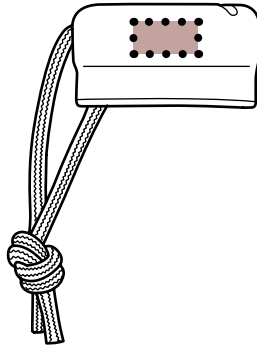

LID - SIDE
20 X 8mm

CUSTOMISATION STYLES

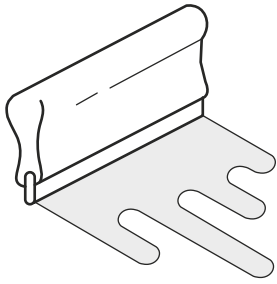

PRINT
(black & white only)



GLASS LUNCH BOWL

WATCH VIDEO

The durable borosilicate glass bowl sits snugly within the microwave-safe and protective base, which is made from polypropylene combined with sustainably-sourced wood fibre. A silicone lid prevents splattering when microwaving, and the stainless steel lid screws onto the base to create a protective and leak proof seal.

Borosilicate glass, 304 - 18/8 stainless steel, silicone, polypropylene with sustainable wood fibre

750 ml
25 oz



PRODUCT COLOUR OPTIONS



ALMOND

SLATE

PRINT OR LASER MARKING AREA

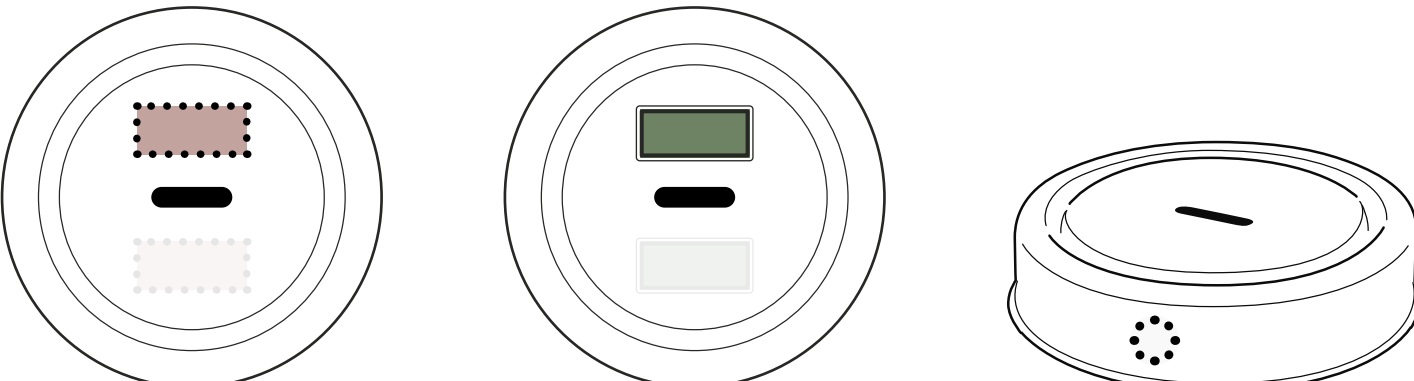

LID - TOP OR BOTTOM
40 X 20mm

LID - TOP OR BOTTOM
40 X 20mm

LID - SIDE
ø20mm

CUSTOMISATION STYLES

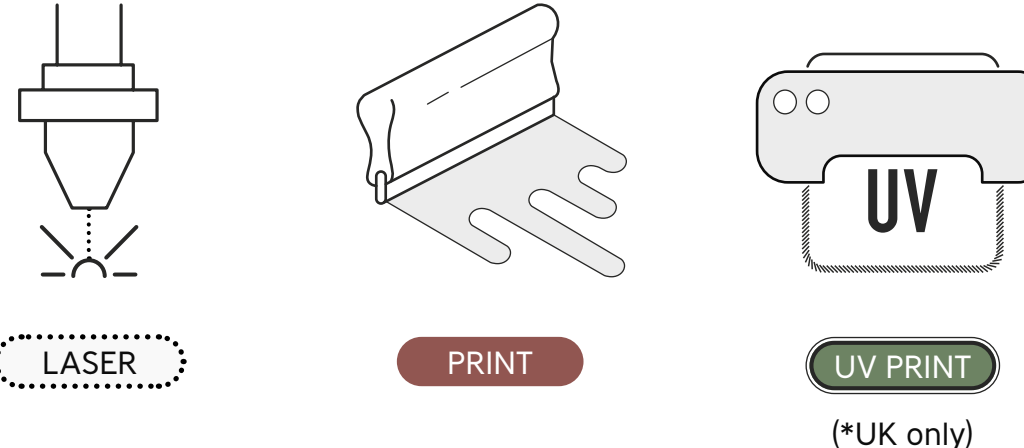

LASER

PRINT

UV PRINT

(*UK only)



GLASS LUNCH POT LARGE

WATCH VIDEO

The durable borosilicate glass pot holds a sizeable lunch portion and sits snugly within the microwave-safe and protective base, which is made from polypropylene combined with sustainably-sourced wood fibre. A silicone lid prevents splattering when microwaving, and the stainless steel lid screws onto the base to create a protective and leak proof seal.

Borosilicate glass, 304 - 18/8 stainless steel, silicone, polypropylene with sustainable wood fibre

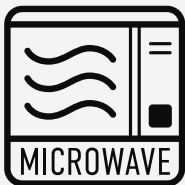

600 ml
20 oz



PRODUCT COLOUR OPTIONS



ALMOND



SLATE



PRINT OR LASER MARKING AREA

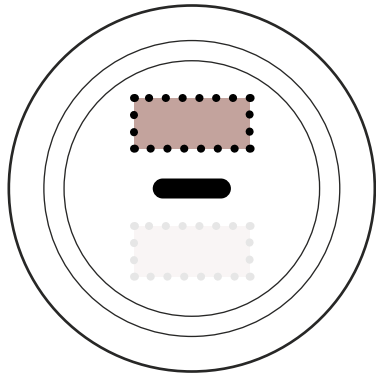

LID - TOP OR BOTTOM
40 X 20mm

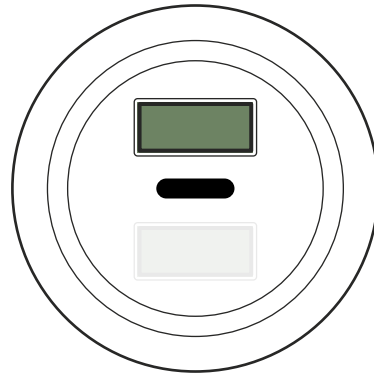

LID - TOP OR BOTTOM
40 X 20mm

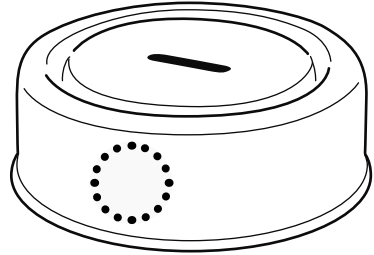

LID - SIDE
ø20mm

CUSTOMISATION STYLES

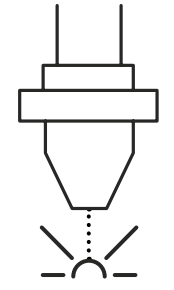

LASER

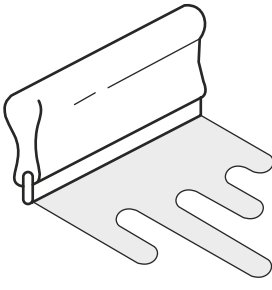

PRINT

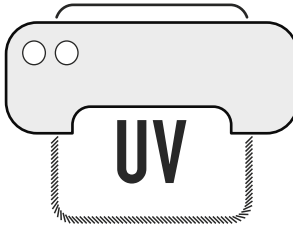

UV PRINT

(*UK only)



GLASS LUNCH POT

WATCH VIDEO

The durable borosilicate glass pot is the smallest of the range and is ideal for breakfasts, sides and snacks. It sits snugly within the microwave-safe and protective base, which is made from polypropylene combined with sustainably-sourced wood fibre. A silicone lid prevents splattering when microwaving, and the stainless steel lid screws onto the base to create a protective and leak proof seal.

Borosilicate glass, 304 - 18/8 stainless steel, silicone, polypropylene with sustainable wood fibre

450 ml
15 oz



PRODUCT COLOUR OPTIONS



PRINT OR LASER MARKING AREA

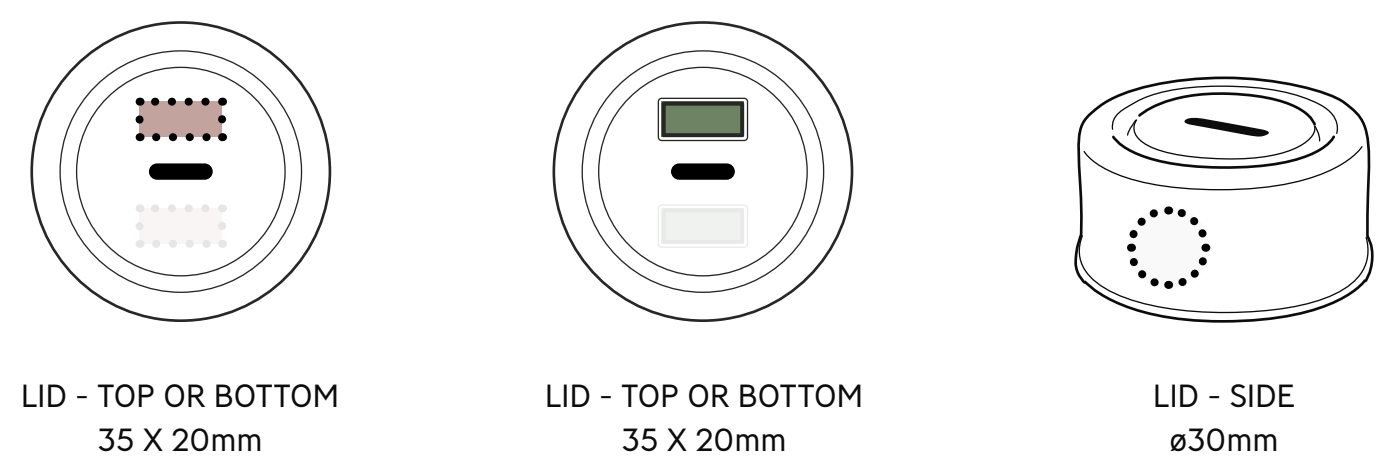

CUSTOMISATION STYLES

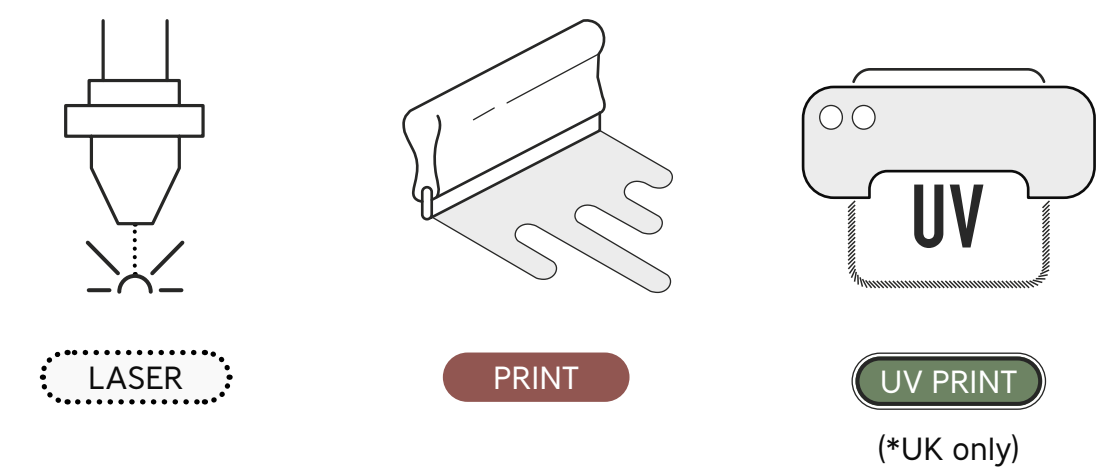

ORIGINALS COLLECTION

The durable borosilicate glass bowl or pot sits snugly within the microwave-safe and protective base, which is made from polypropylene combined with sustainably-sourced wood fibre. A silicone lid prevents splattering when microwaving, and the stainless steel lid screws onto the base to create a protective and leak proof seal.





LUNCH BOX ORIGINAL

WATCH VIDEO

The Lunch Box Original includes an inner container as well as a leak proof sauce pot with a garnish area in the lid, and a stainless steel fork. Microwave-safe and fully leak proof, this is one of the most versatile lunch boxes in our entire range.

Polypropylene, Tritan™, 304 - 18/8 stainless steel, silicone

1 L
34 oz



PRODUCT COLOUR OPTIONS



OLIVE



OCEAN



PRINT AREA

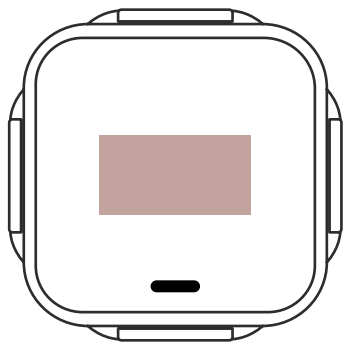

LID
80 X 50mm
(*UK and EU only)

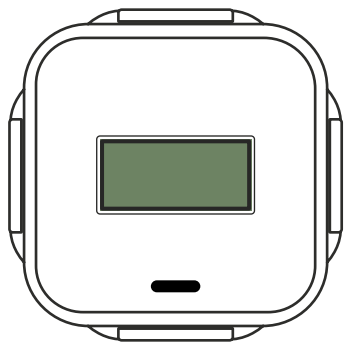

LID
80 X 50mm



LID - CLIPS
40 X 15mm



FORK
50 X 10mm

CUSTOMISATION STYLES

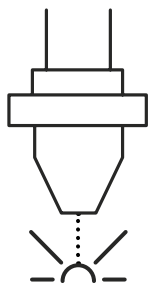

LASER

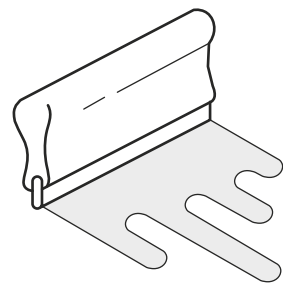

PRINT

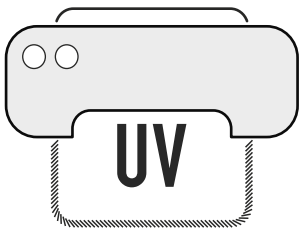

UV PRINT

(*UK only)



LUNCH POT ORIGINAL

WATCH VIDEO

The Lunch Pot Original consists of two leak proof pots that can be locked together for carrying. The pots have a convenient silicone carrying strap which also holds the stainless steel 'spork' (spoon and fork). Separate anything from yoghurt and fruit to noodles and soup. When you're finished, the smaller pot fits inside the larger pot for easy storage.

Polypropylene, Tritan™, 304 - 18/8 stainless steel, silicone

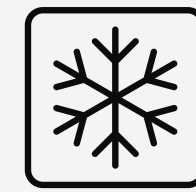

600/300 ml
20/10 oz



PRODUCT COLOUR OPTIONS



OLIVE



OCEAN



PRINT AREA

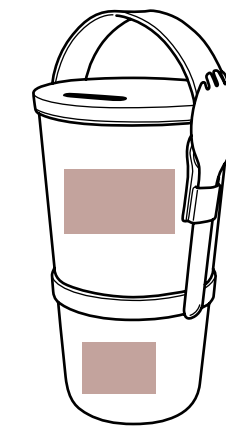

LARGE POT
60 X 35mm
(*UK and EU only)

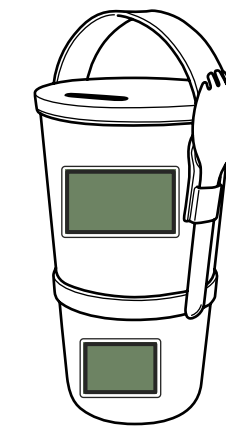

SMALL POT
45 X 30mm

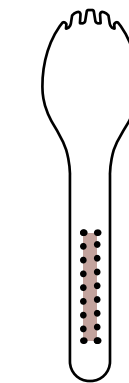

SPORK
50 X 10mm

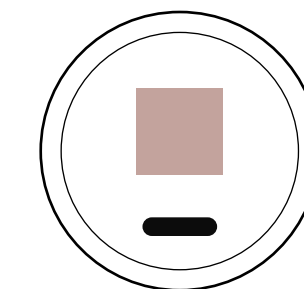

LID
40 X 40mm
(*UK and EU only)

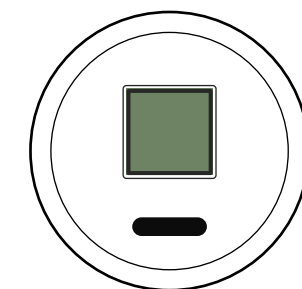

LID
40 X 40mm

CUSTOMISATION STYLES

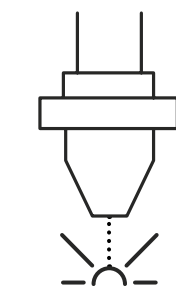

LASER

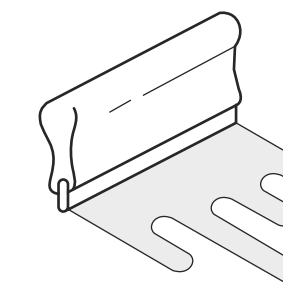

PRINT

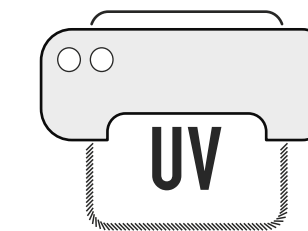

UV PRINT

(*UK only)

CHARCOAL FILTRATION

Activated charcoal has been used for centuries to remove toxins, treat digestive ailments, and filter drinking water. We quickly realised that using it in tap water not only made it taste delicious, but it completely eliminated the need for bottled water, and the single-use plastic that comes with it. What began with one bottle has quickly expanded to an entire range, with charcoal filtration being one of our best-selling collections.

We source our charcoal from the skilled artisan makers of Laos as they follow strict conservation rules to protect the surrounding forests. The fast-growing native trees are pruned and the wood is transported to the kiln. It is stored there for 1 month untouched to dry the wood. It is placed inside the kiln and burned until it reaches 1200°C to make it red-hot and carbonised. The charcoal is removed and quickly covered with a powder made from earth, sand and ash, and this gives the charcoal surface a whitish hue. This process, which takes 21 days, produces what is called 'Binchotan' charcoal. The rapid rise in temperature, followed by a quick cooling, incinerates the bark and leaves a smooth, hard surface, and creates a product which can be used for deodorising, dehumidifying and filtering water.





EAU GOOD

WATCH VIDEO

Our iconic water bottle comes with an active charcoal filter that locks easily in place, thanks to the innovative squeeze-and-lock charcoal groove. The natural cork lid with stainless steel closing ring is watertight, and the colourful fabric loop makes it easy to carry.

Tritan™, 304 - 18/8 stainless steel, nylon, silicone, natural cork



800 ml
27 oz



PRODUCT COLOUR OPTIONS



OLIVE

LIME

BLACK

BLUE

RED

PRINT AREA

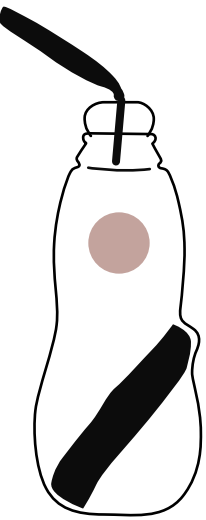

UPPER BODY
ø30mm

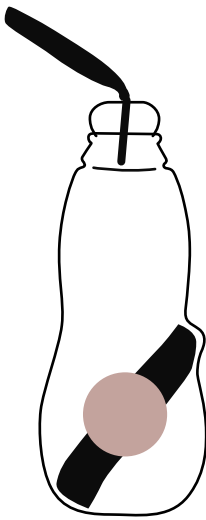

LOWER BODY
ø40mm

CUSTOMISATION STYLES

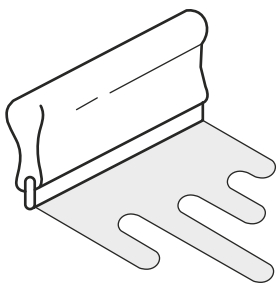

PRINT

ACCESSORIES

Our accessories have been designed to pair with our main product ranges. From a reusable cutlery set, to a recycled PET Lunch Bag or even a recipe book, they are easy to add to any purchase.





CUTLERY SET & CASE

WATCH VIDEO 

This stacking knife, fork and spoon set feels at home in your hands, and conveniently nests into a hygienic, compact carry case.

304 - 18/8 Stainless steel, polypropylene

QUALITY
STAINLESS
STEEL



BPA
FREE



PRINT OR LASER MARKING AREA

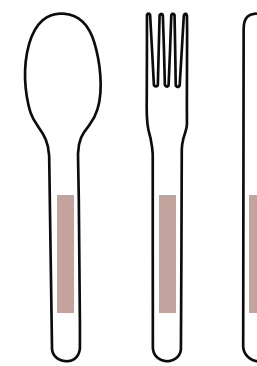

CUTLERY - FRONT
75 X 10mm

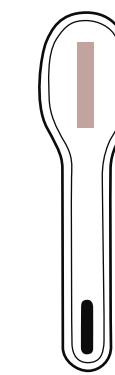

CASE - TOP
45 X 20mm
(*UK and EU only)

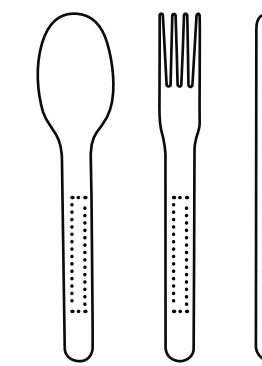

CUTLERY - FRONT
75 X 10mm



CUSTOMISATION STYLES

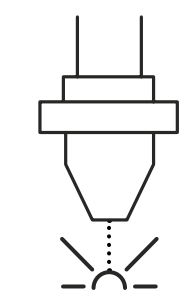

LASER

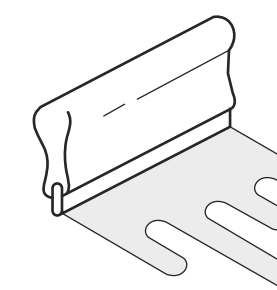

PRINT



LUNCH BAG

WATCH VIDEO

With a generous capacity of 6.7L and made from recycled plastic bottles, this lunch bag is all you need to carry your breakfast, lunch and snacks for the day. The sealed insulated construction keeps the contents cool, it's also leak proof, water repellent and easy to wipe clean. The rolldown top and clip make it easy to carry, you can even strap it to your bike or backpack.

Iron (hook), polypropylene (strap), recycled PET (outer fabric), PEVA (BPA and food safe inner lining)



6.7 L
235 oz



PRODUCT COLOUR OPTIONS



OLIVE



SLATE



PRINT AREA

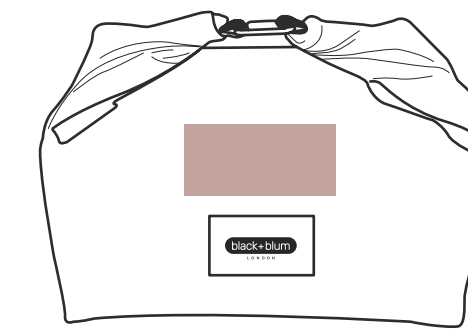

FRONT
150 X 70mm

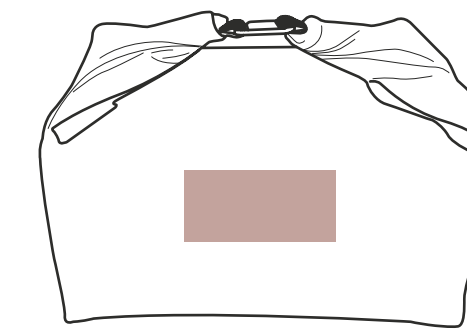

BACK
150 X 70mm

CUSTOMISATION STYLES

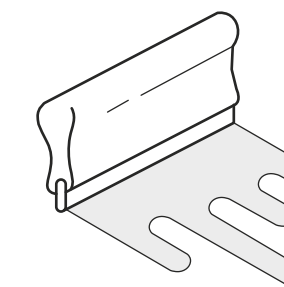

PRINT

(screen print, single colour)

FAQ

HOW TO ORDER?

Email sales@black-blum.com and fill in the listed questions:

- + Product name and colour
- + Product quantity
- + Sample required
- + Attach artwork
- + Specify artwork position on product
- + Delivery Address (contact name, email and telephone number)
- + Deadline

PACKAGING

All prices include our standard Black+Blum branded packaging, but it is possible to have the products without packaging upon request, or custom packaging is available for orders over 1000 units.

PRICING

Quoted prices include UK shipping to your designated delivery address from our UK warehouse, EU and US shipping cost will be calculated separately. Prices do not include VAT (where applicable).

PAYMENT

All quotes are Proforma and must be paid in full, before an order can commence.

MOQ

The minimum order quantity is 100 products per item.

PRODUCTION TIME

We endeavour to keep all products in stock and where possible keep within 30 working days turnaround, from pro-forma payment.

SHIPPING/STOCK

We hold stock in the UK, EU and US and custom brand locally. UK shipping cost is included, but for EU and US it will be calculated separately.

VOLUME DISCOUNTS

We will provide price breaks for quantities of 100, 200, 500 and 1000. Additional savings may be available for orders over 1000+ pieces.

ARTWORK

Supply in .ai, PDF or EPS (always vectorised logos). We can use this to create a digital proof to show you how the design will look.

ARTWORK SIZE

All the printing areas shown in our brochure are the maximum printing size, but your artwork/logo can be smaller than these size guides.

SAMPLE

We can normally supply a sample of your custom branded product within 1-2 weeks. The cost of this sample will be refunded on volume order payment.

black+blum

L O N D O N

 black-blum.com

 [@blackblumdesign](https://www.instagram.com/blackblumdesign)

 [Black+Blum](https://www.facebook.com/Black+Blum)

 [black and blum](https://www.youtube.com/blackandblum)

